



Supplementary agenda

Mousehold Heath Conservators

Date: **Friday, 19 January 2024**
Time: **14:30**
Venue: **Mancroft room City Hall, St Peters Street, Norwich, NR2 1NH**

Committee members:

Councillor Sands (M) (chair)
Councillor Peek (vice chair)
Councillor Carrington
Councillor Champion
Councillor Fox
Councillor Francis
Councillor Kendrick
Councillor Kidman
Councillor Lubbock
Marion Maxwell, Mousehold Heath
Defenders
Willem Buttinger, The Norwich Society
1 Vacancy

For further information please contact:

Committee officer: Leonie Burwitz
t: (01603) 989255
e: leonieburwitz@norwich.gov.uk

Democratic services
City Hall
Norwich
NR2 1NH

www.norwich.gov.uk

Information for members of the public

Members of the public and the media have the right to attend meetings of full council, the cabinet and committees except where confidential information or exempt information is likely to be disclosed, and the meeting is therefore held in private.

For information about attending or speaking at meetings, please contact the committee officer above or refer to the council's website.



If you would like this agenda in an alternative format, such as a larger or smaller font, audio or Braille, or in a different language, please contact the committee officer above.

Agenda

Page nos

9 Mousehold Heath toilet refurbishment

3 - 14

Purpose - The purpose of this report is to identify a practical solution for the refurbishment of the existing male and unisex accessible toilets located next to Zaks Restaurant on Mousehold Heath to provide an improved public toilet provision for the users of Mousehold Heath.

Date of publication: **Monday, 15 January 2024**



Committee name: Mousehold Heath Conservators

Committee date: 19/01/2024

Report title: **Mousehold Heath toilet refurbishment**

Portfolio: Councillor Giles, Cabinet member for communities and social inclusion

Report from: Head of environment services

Wards: **Catton Grove and Crome**

OPEN PUBLIC ITEM

KEY DECISION

Purpose

The purpose of this report is to identify a practical solution for the refurbishment of the existing male and unisex accessible toilets located next to Zaks Restaurant on Mousehold Heath to provide an improved public toilet provision for the users of Mousehold Heath.

Recommendation:

It is recommended that

- a. The existing male toilets are changed to a single unisex toilet and the existing male disabled toilet is refurbished as detailed in section 8 at an estimated cost of £30,566.16
- b. An external consultant is engaged to conduct a feasibility study to identify
 - i. The optimum location for a changing places facility within Mousehold Heath, having regard to the needs of visitors to Mousehold Heath and accessibility
 - ii. The enabling works required for the preferred location, e.g. access, utilities, and
 - iii. A cost estimate for such a facility
- c. The refurbishment of the toilets should include LED lighting, hygienic PVC clad walls, non-slip flooring, water heater, hand dryer and a stainless steel toilet, wash hand basin, grab rails and a baby changing station.

Policy framework

The council has five corporate priorities, which are:

- People live independently and well in a diverse and safe city.
- Norwich is a sustainable and healthy city.
- Norwich has the infrastructure and housing it needs to be a successful city.
- The city has an inclusive economy in which residents have equal opportunity to flourish.
- Norwich City Council is in good shape to serve the city.

This report meets the sustainable and healthy city corporate priority.

This report addresses Deliver a Capital Investment Programme in our parks that will improve visitor experience, maintain our heritage assets and improve community cohesion. strategic action in the Corporate Plan.

The report helps to meet the Mousehold Heath management plan:

Objectives A: To ensure Mousehold Heath is a welcoming place for people to visit.

Objectives C: To ensure that Mousehold Heath is clean and well maintained

Report details

1. Background

- 1.1. The existing toilet facilities on Mousehold Heath are in poor condition. Discussions regarding the refurbishment of the toilets have been ongoing for over a year.
- 1.2. It has been previously suggested that the most practical solution for improving toilet facilities at Mousehold Heath is to refurbish the toilet block that currently provides the male and accessible toilets.

2. The Building

- 2.1. The building is situated to the left (West) of the Mousehold Pavilion. It is single storey and is constructed of single brick thick lower walls with tongue and groove timber cladding forming the upper section of the walls. The roof is pitched and covered with traditional tiles. The council does not hold records of the year the toilet block was constructed however the photo below which is understood to have been taken in 1938 shows the building in situ and can be recognised by the detailed roof ridge line which is still present to this day.
- 2.2. The building is in need of external redecoration and repairs to the rotten timber cladding and rainwater system are required.



3. Existing Layout

- 3.1. The building is currently halved, with one half of the building serving as the gentleman's toilet which contains two toilet cubicles and a single wash hand basin.
- 3.2. The adjacent half of the building is a single accessible unisex toilet, which has recently been allocated to include the use for ladies facilities following the closure of the ladies toilets which were located on the opposite side of the pavilion due to their poor condition.
- 3.3. The photos below show the current condition of the existing toilet facilities. The toilet block does not have an electrical supply, therefore there is no lighting, warm water for hand washing or hand drying facilities.





4. Existing Floor Plan

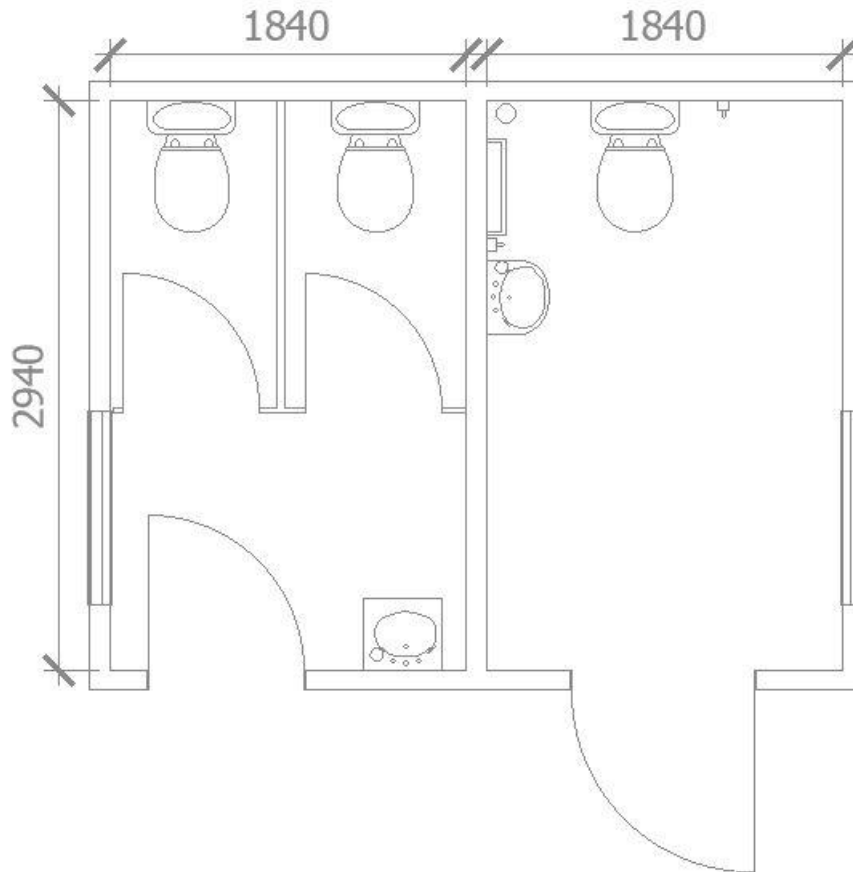

5. Proposed Specification

Internal

- Sensor LED lighting
- Hygienic PVC clad walls
- Non-slip flooring
- Water heater
- Hand dryer
- Stainless steel toilet
- Wash hand basin
- Grab rails
- Baby changing station

External

- Full external redecoration and lighting

6. Changing Places Accessible Toilet Specification

6.1. A request has been made by members of the Household Conservators for the refurbished toilets to include a Changing Places Accessible Toilet Specification. In addition to the grab rails provided within a standard accessible toilet, a Changing Places Accessible Toilet Specification also includes a hoist and adult sized height adjustable changing table.

- 6.2. National guidance states that the dimensions of a Changing Places Accessible Toilet should be a minimum 4000x3000mm in size to ensure there is adequate space for a disabled person out of their wheelchair, their wheelchair and up to 2 carers to comfortably use the facility. The existing accessible toilet dimensions are only 2840x1740mm and are therefore not of adequate size to meet minimum recommendations.
- 6.3. Guidance also recommends that wherever possible, Changing Places toilets should be incorporated into existing facilities. Where this is not possible, modular facilities can be provided. In any case, providers of Changing Places facilities should have regard to access routes, in particular width, gradients and surfaces. Access routes should be weather-proof, and level access is preferable. Finally, ability to drop off visitors using a wheelchair from a vehicle is encouraged.
- 6.4. Unfortunately, the location currently being proposed for the Changing Places does not meet these criteria. It is therefore proposed that Conservators engage a consultant to carry out a feasibility study for a Changing Places facility on Mousehold Heath. This would have the benefits of:
- a. Allowing refurbishment of the existing Gents' toilet block to proceed as outlined in Section 8, and
 - b. Ensuring that any Changing Places facility provided full complies with current guidance

7. Refurbishment Proposal

7.1. The property services team recommends the refurbishment of the existing male and accessible toilets into two unisex toilet facilities.

7.2. It has been previously discussed that as the newly formed unisex toilet will be of sufficient size to accommodate a standard disabled toilet and fittings, that this toilet should also be refurbished to an accessible toilet standard.

7.3. However, the existing door opening is narrow and the threshold is not level to provide sufficient access for people with mobility issues into the toilet. The property services team has asked the question if there is the demand for use for a second disabled toilet facility on Mousehold Heath given the additional costs required to increase the size of the door opening, supply a larger lintol, provide a new door, create a level access threshold and additional hand/grab rails.

Proposed Floor Plan

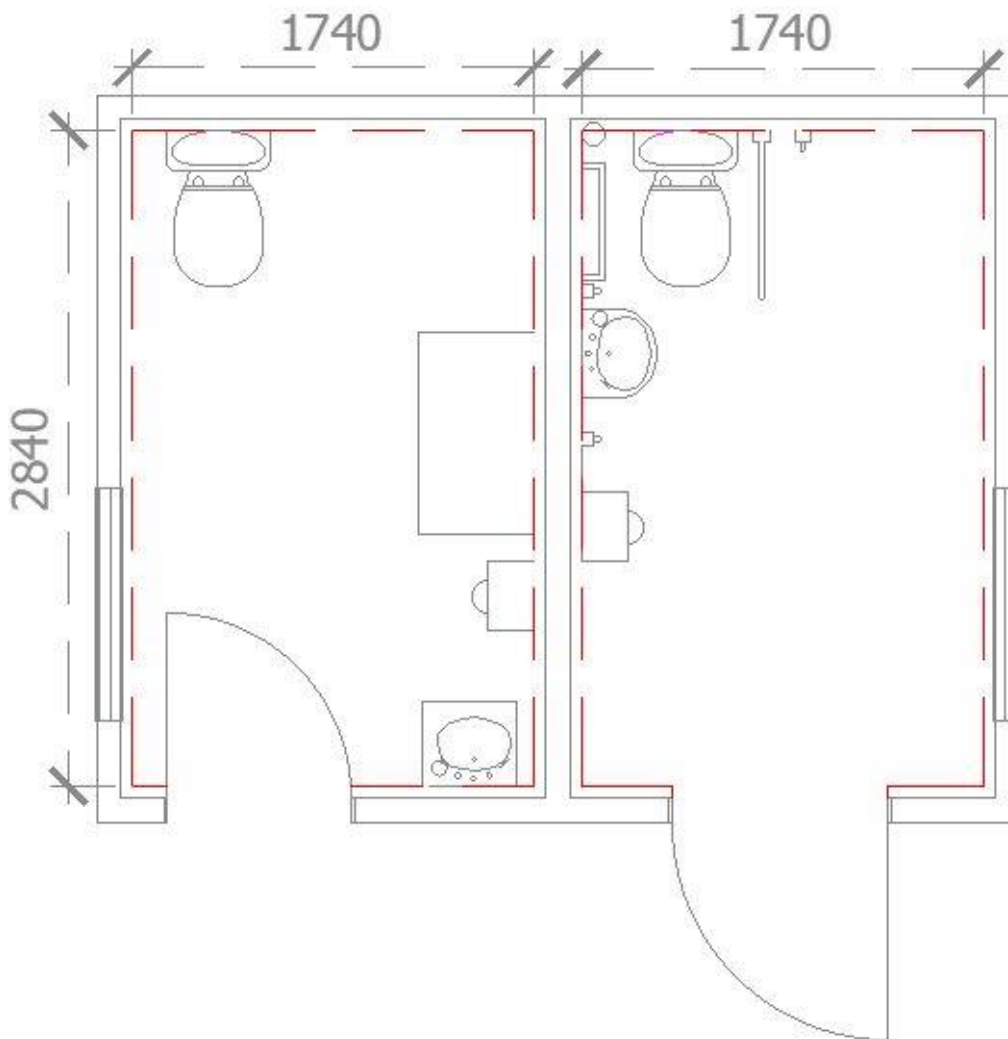

Floor plan – showing dimensions of the toilets and a person in a wheelchair

7.4. The boxed hatching is 700x1200 (size of a wheelchair). This floor plan shows the lack of available space to accommodate both a wheelchair user, hoist and adult adjustable changing table.

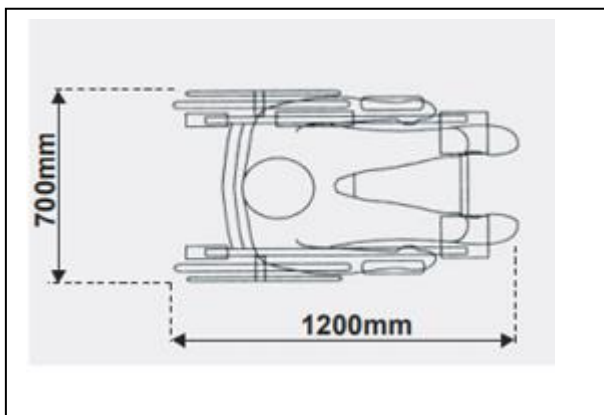
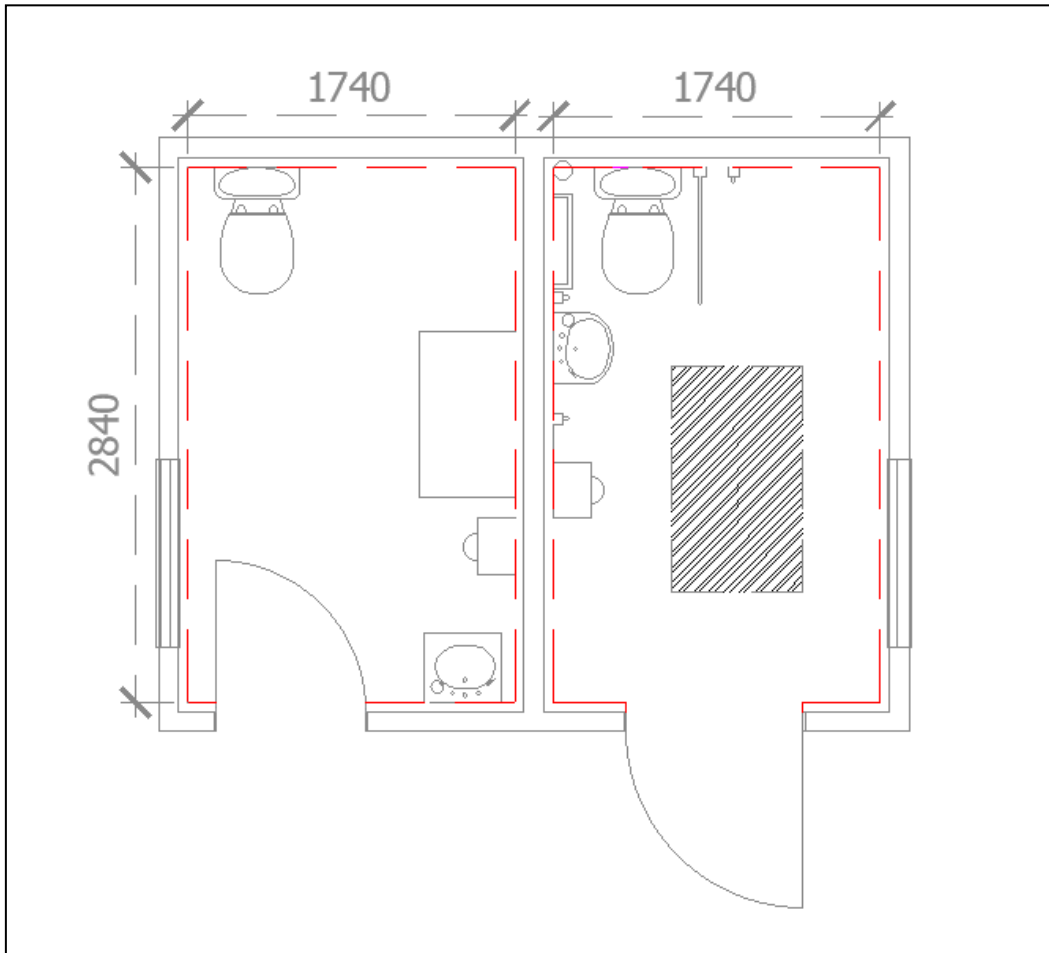

Proposed Visual Image of Refurbished Accessible Toilet



Nb. Finishes may differ to image. This is for visual representation only.

8. Budget Estimates

Refurbishment of Existing Gentleman's Toilet to Include:

- Strip out of all internal fittings
- Stud, insulate, ply and apply hygienic PVC cladding to walls
- Prepare floor, latex and non-slip floor covering
- Pipework and plumbing accessories
- Install stainless steel toilet, basin and grab rails
- Install baby changing table
- Install hand dryer
- Install water heater

Budget Estimate £11,172.63

Additional Works Required to Create Accessible Toilet Facility

- Widen existing doorway to accept new DDA compliant door
- Install wooden lintol
- Install new door and frame
- Reduce threshold level

Budget Estimate £1653.07 **Cost not included in total below**

Refurbishment of Existing Accessible Toilet to Include:

- Strip out of all internal fittings
- Stud, insulate, ply and apply hygienic PVC cladding to walls
- Prepare floor, latex and non-slip floor covering
- Pipework and plumbing accessories
- Install stainless steel toilet, basin and grab rails (Doc M pack)
- Install hand dryer

Budget Estimate £9,393.53

External Redecoration

- Timber repairs prior to redecoration
- Gutter repairs
- Timber preparation prior to redecoration
- Undercoat
- Two topcoats

Budget Estimate £4,000

Electrical supply

- Submeter from Zaks Restaurant
- Lighting

Budget Estimate £6,000

Total Budget Estimate £30,566.16

Plus 20% Contingency sum of £6,113.04

Implications

Financial and resources

9. Any decision to reduce or increase resources or alternatively increase income must be made within the context of the council's stated priorities, as set out in its Corporate Plan 2022-26 and budget.

10. The cost of the refurbishment of the toilets will come out of the Mousehold Heaths Conservators reserves as agreed at previous Conservators Meeting.

Legal

11. None

Statutory considerations

Consideration	Details of any implications and proposed measures to address:
Equality and diversity	No change, as the refurbishments will continue to provide toilet facilities for all users
Health, social and economic impact	Improved and updated toilet facilities for all users
Crime and disorder	The Mousehold Wardens will continue to work with Norfolk Constabulary to ensure that the Heath is a safe place to visit
Children and adults safeguarding	Safeguarding is a priority for the Mousehold Wardens, and they will continue to signpost vulnerable individuals to the services that they require.
Environmental impact	The only change will be connecting the toilets up to an electrical supply, for lighting, heating water and hand dryer.

Risk management

Risk	Consequence	Controls required
Financial	Failure to adequately plan and monitor the implementation of the toilet project can have an impact on the budget.	Agree costs at the start. Include a contingency budget. Correct management of the project

Other options considered

12. The installation of a changing places accessible toilet was fully investigated. The toilet size did not meet the standards required for a changing places accessible toilet.
13. Recommendation to agree the findings of the report and agree to the refurbishment of the toilets to provide a unisex and disabled toilet facility.

Appendices: None

Contact officer:

Name: Mark Brzeczek

Email address: markbrzeczek@norwich.gov.uk



If you would like this agenda in an alternative format, such as a larger or smaller font, audio or Braille, or in a different language, please contact the committee officer above.